

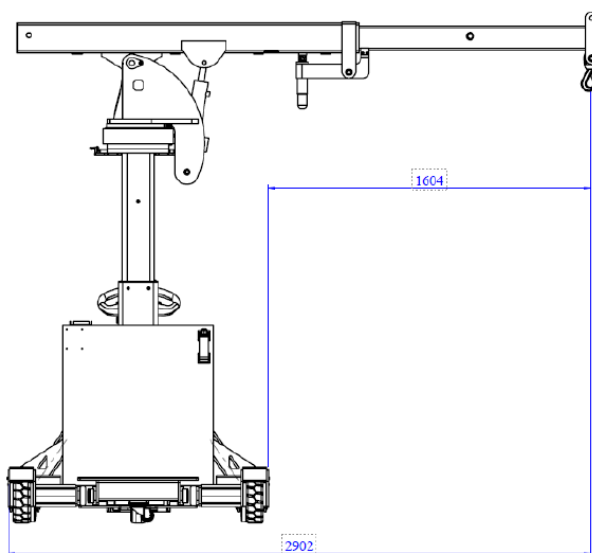

Technical Data Sheet I2MO RI80 v4 TC

Self-propelled workshop mini-crane with accompanying operator

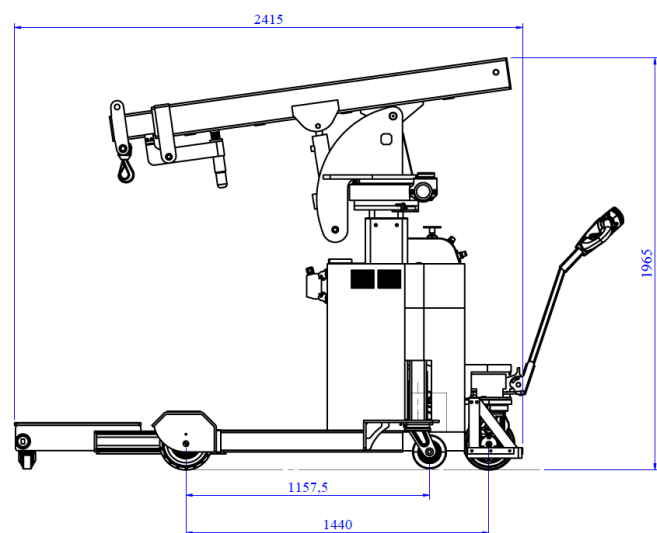
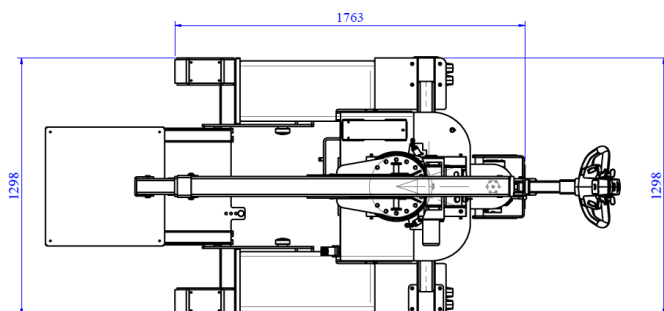
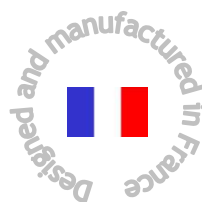

Technical characteristics



- Max. load 500 kg
- Unladen weight 1270 kg
- Traction batteries 24V – 180 Ah
- Central hydraulic motor 2.2 kW
- Translation motor 0.7 Kw

Standard equipment

- Hydraulic proportional control valve
- Retractable hydraulic loading platform
- Hydraulic 180° rotating head
- Hydraulic jib tilting
- 600 mm hydraulic vertical mast stroke
- 1000 mm hydraulic telescope stroke
- Electric traction with speed controller
- Drawbar with accelerator and emergency reverse
- Wired remote control with potentiometer emergency stop
- Hourmeter and battery charge indicator
- Wheels and castors with rubber tread
- Hydraulic & electrical safety devices
- Anti-tip devices
- On-board battery charger

Options

- Various additional booms and accessories
- Electric winches

Diagram
12MO Evolutive R180 v4 TC&PC
 Boom in position $\pm 0^\circ$ to $\pm 90^\circ$
 Mast retracted or extended

