

The 30MT 3x1 TC model is a compact and powerful mini-crane. It integrates a short jib with a hydraulic telescope. The jib is mounted on an 18° slewing ring (Option).

Designed with solid resilient tires and **adjustable and removable safety stands** this model fits for safe outdoor lifting operations.

It uses a **3-cylinder kinematic system** developed by Mobilev Cranes allowing for greater angular motion of the jib.

All speeds are adjustable from 0 to 100% with the wired remote control or with the radio remote control (optional).

(**) SRT : Solid Resilient Tires

Update September 21st, 2020



Patented Kinematic

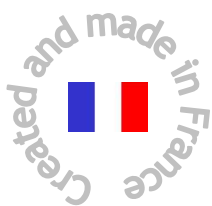

1600 with safety stands
960 safety stands removed

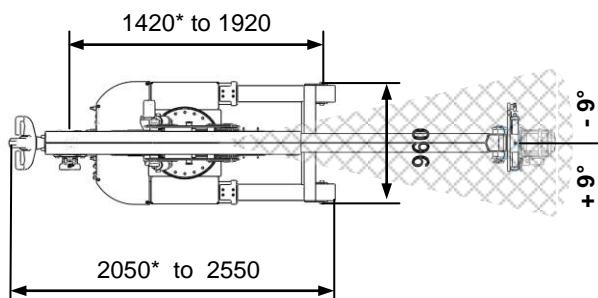

* With variable wheelbase

Technical specifications



Maxi load	3000 kg
Unladen weight (without options)	2100 kg
Admissible slope (unladen crane).....	18 %
Maxi translation speed	3 km/h
Adjustable lifting speed	from 0 to 15 cm/s
Adjustable telescoping speed	from 0 to 13 cm/s
Batteries	24V – 460 Ah
24V cc silent motor driven pump	4.5 kW
Ø front wheels (mm)	4 x 310 mm
Ø rear wheel (mm)	1 x 523 mm

Standard equipment

- Anti-tilt system
- 1 hydraulic drive wheel
- Rubber coating wheels and SRT**
- Hydraulic telescopic jib
- Hydraulic drive assistance
- Automatic braking system
- Automatic parking brake
- Adjustable and removable safety stands
- Integrated electronic battery charger 220V~
- Wired remote control with potentiometer
- 2 storage boxes

Main options

- Additional jib 500 kg
- Additional jib with winch 500 kg
- Additional jib with manual telescope 500/350 kg
- Additional jib with manual telescope 350/250 kg
- Hydraulic winches (2600, 1000, 500 kg)
- 18° slewing ring OR sliding table for hook's lateral displacement
- Variable wheelbase

Technical sheet 30MT 3x1 TC

« All-road » Self-propelled mini-crane with accompanying operator

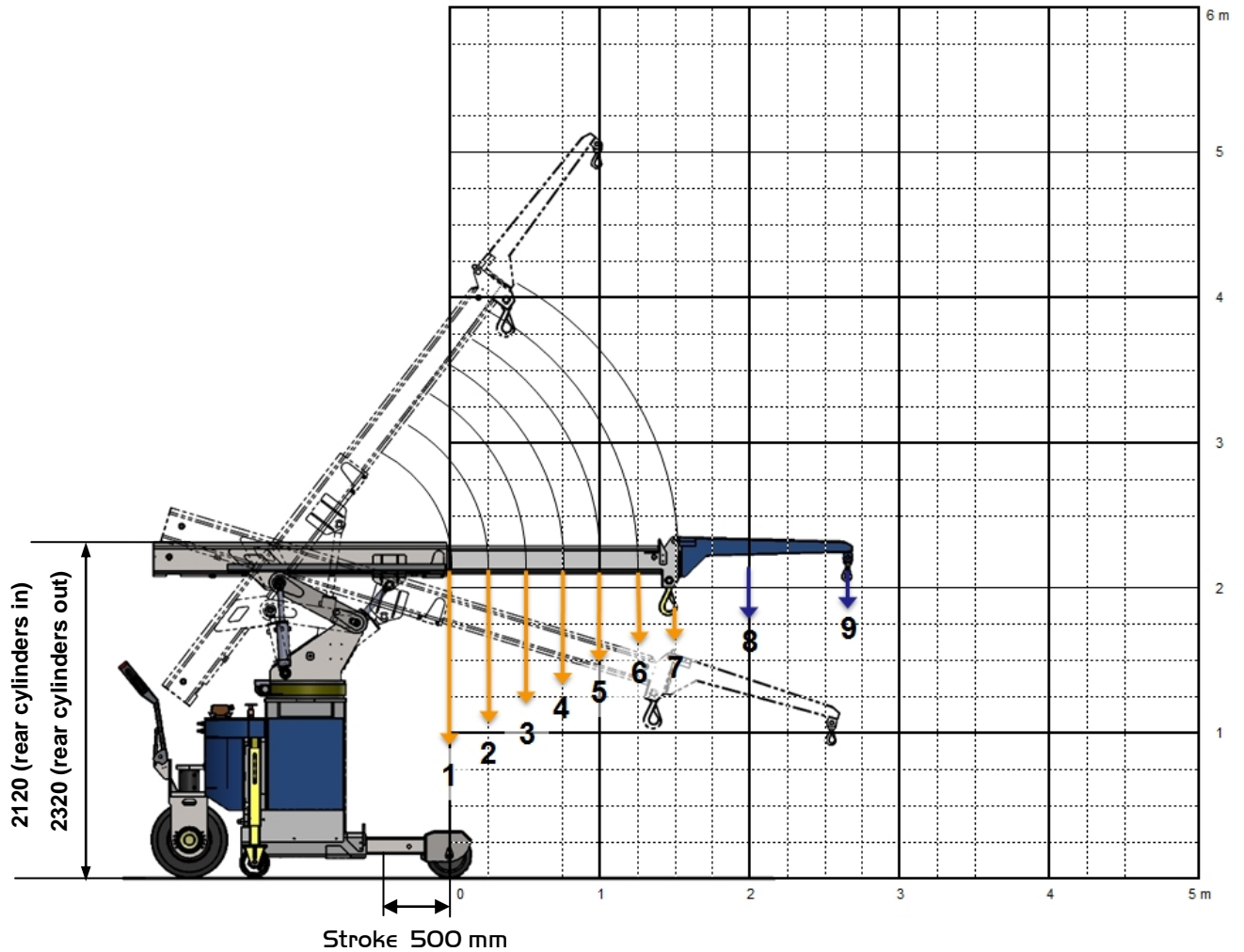

	1	2	3	4	5	6	7	8	9
Distance front wheels / axle (mm) Variable wheelbase OUT	0	250	500	750	1000	1250	1440	2000	2630
Capacity with variable wheelbase OUT (kg)	3000	2500	2140	1850	1620	1440	1270	960	700
Distance front wheels / axle (mm) Variable wheelbase IN	500	750	1000	1250	1500	1750	1940	2500	3130
Capacity with variable wheelbase IN (kg)	2540	1750	1180	900	760	620	540	430	310



Variable wheelbase option
Stroke 500mm



4 axes wired remote control
with potentiometer