

Updated September 21<sup>st</sup> 2020

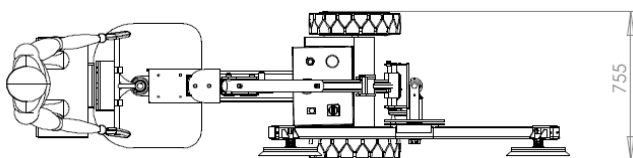
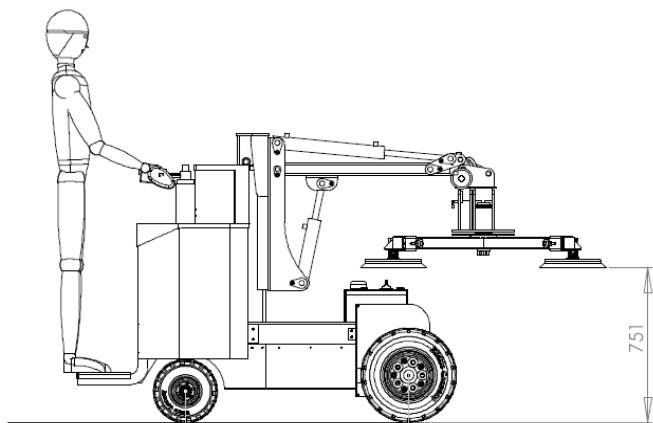
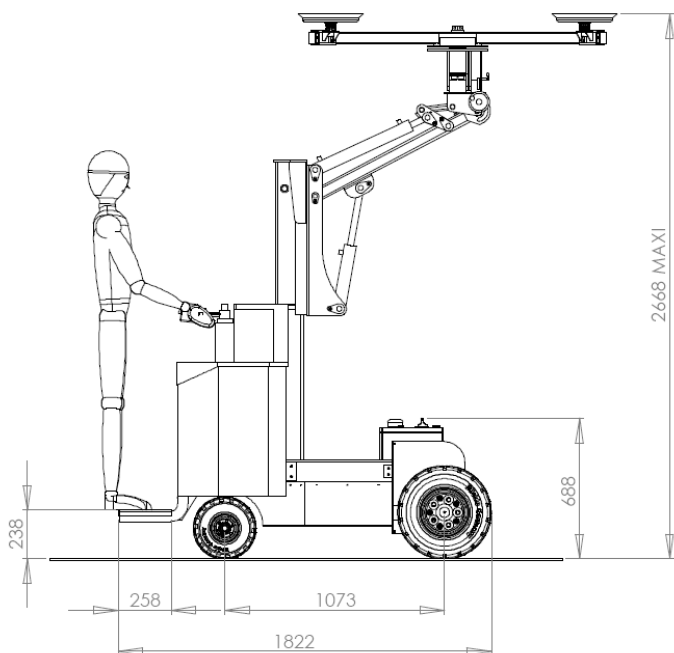

### Technical specifications

Maximal load .....	350 kg
Unladen weight (Full options) .....	610 kg
Traction batteries .....	24V – 110 Ah
Hydraulic power station engine .....	2 kW
Translation power engine.....	0,6 kW
Unladen admissible slope .....	15 %

(\* ) Mini-crane created and made by Mobilev, vacuum lifting beam created and made by Axitec

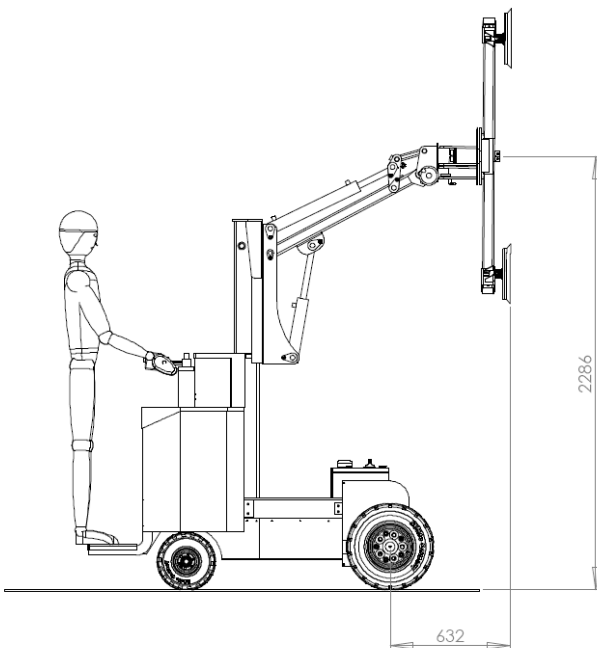
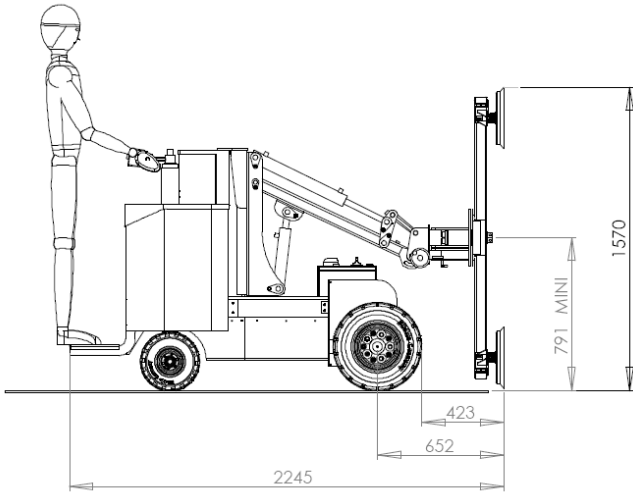

### Standard equipment

- Vertical hydraulic mast 700 mm stroke
- Vacuum lifting beam with 180 ° hydraulic tilt
- Electric front wheel drive with differential gear
- Brake-operated
- Automatic, electric or manual disconnection of the brake
- Tiller with accelerator
- Folding operator platform
- Vacuum lifting beam (360 ° continuous manual rotation)
- Vacuum reserve and alarm
- Vacuum pump securely with automatic restart
- Remote pick and place
- Hour meter and battery charge indicator
- Charger board electronic
- Tyre puncture-proof wheels Full Flexible
- buzzer
- Axes slinging
- Hydraulic & electric safety devices